



Instr. No. 2650-440B

# INSTALLATION INSTRUCTIONS PRO-SHIFT LITE MODEL: 19206



## Features

- High accuracy-Custom RPM Modules (Pills).
- Order separately in different RPM ranges with 5 modules per pack at 200 rpm intervals.
- New super bright red LED provides instantaneous notice of shift points.
- Easy to select 1 or 2 pulse operation.
- User choice of options for mounting.
- Self-test feature flashes LED when power is turned on.

## Module Kits

RPM Modules are available in 200 RPM increments from 5000 to 13,800 RPM. They are supplied in kits of 5.

RPM Model Kit Model Numbers;	Description	
5355	5000 RPM	(50, 52, 54, 56, 58 x 100 RPM)
5356	6000 RPM	(60, 62, 64, 66, 68 x 100 RPM)
5357	7000 RPM	(70, 72, 74, 76, 78 x 100 RPM)
5358	8000 RPM	(80, 82, 84, 86, 88 x 100 RPM)
5359	9000 RPM	(90, 92, 94, 96, 98 x 100 RPM)
5360	10,000 RPM	(100, 102, 104, 106, 108 x 100 RPM)
5361	11,000 RPM	(110, 112, 114, 116, 118 x 100 RPM)
5362	12,000 RPM	(120, 122, 124, 126, 128 x 100 RPM)
5363	13,000 RPM	(130, 132, 134, 136, 138 x 100 RPM)

## Cylinder Sel

Place switch in desired mode of operation (1 pulse/rev or 2 pulse/rev)

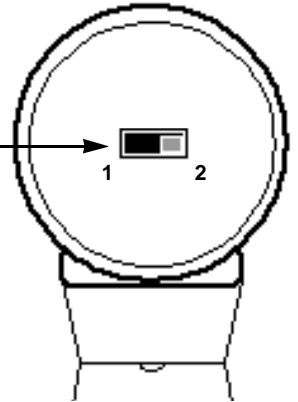

## Wiring

### Standard Ignition Model 19206

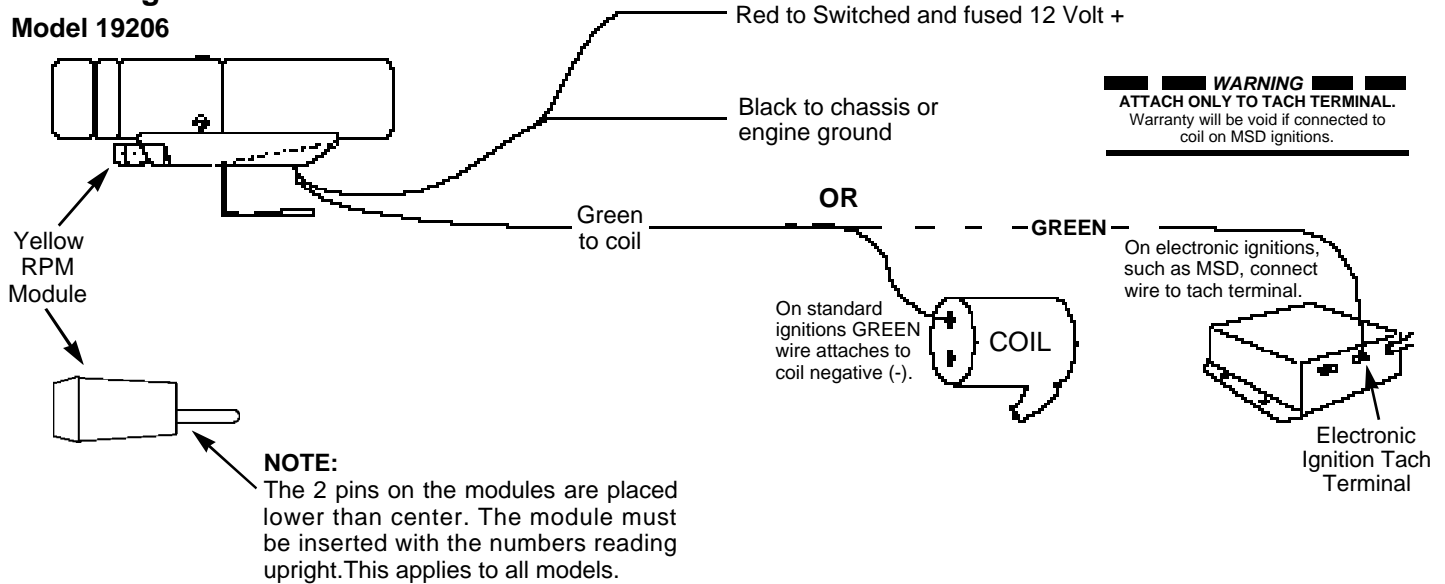

### Harley Davidson Single Flame Ignition

**NOTE:** This Shift Lite operates on standard, factory electronic and high performance electronic ignitions, such as Dyna-S and MSD. Not for use on Super mag Ignitions or any other type of magneto ignitions. On electronic ignitions, connect green wire to tach terminal.

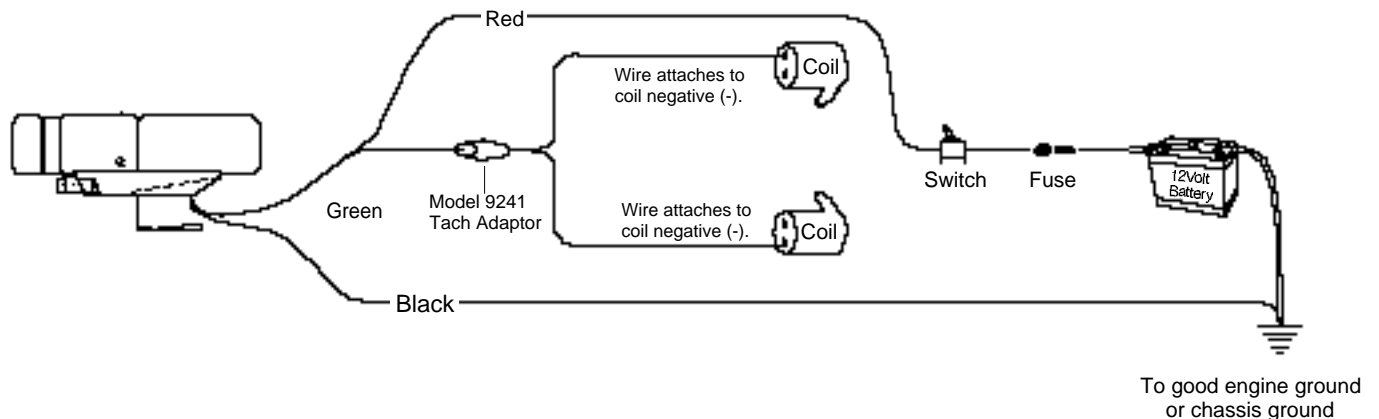

## Mounting

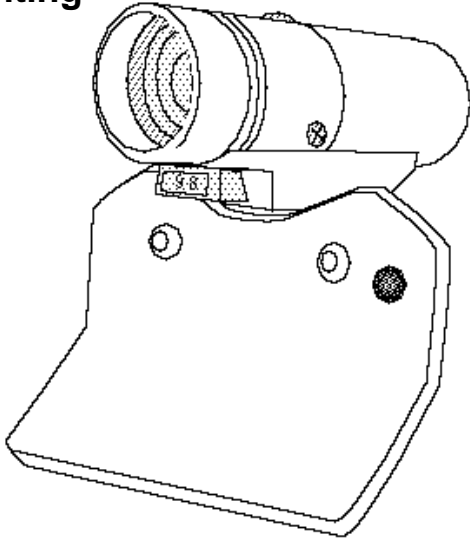

## On Your Motorcycle

1. Drill holes in motorcycle bracket to match the mounting holes on your triple tree.
2. Bolt the motorcycle bracket securely in place.
3. Remove original Pro-Shift Lite mounting bracket and replace it with the 19242 Pro-Shift Lite mounting bracket supplied in the accessory kit.
4. Line up the Pro-Shift Lite mounting bracket with the holes on the motorcycle bracket. Insert the two 1/4"-20 button head screws through the holes in the mounting brackets. Tighten using two 1/4"-20 acorn nuts.

## Mounting

### On Your Pro Cycle Tachometer

It is not necessary to remove the base from the Pro-Shift to accomplish proper mounting. For tach mounting, loosen the shock strap, slip the base under the inner strap and re-tighten the strap assembly.

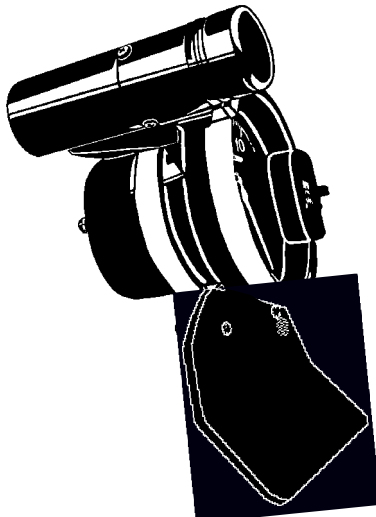

### Other Mounting Option

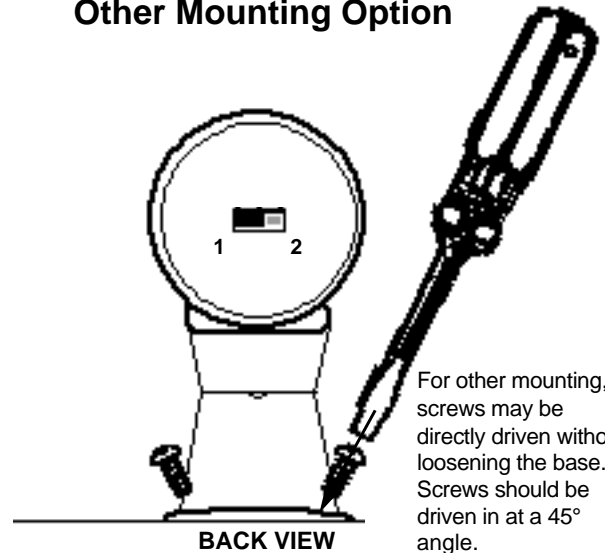

For other mounting, screws may be directly driven without loosening the base. Screws should be driven in at a 45° angle.

## Initial Testing

1. Insert low RPM pill module included with the PROSHIFT for testing.
2. Turn power on. LED should turn on briefly. This will not happen without a module inserted in product.
3. Start engine and free rev to the module RPM. LED will turn on, and stay on, at and above the set RPM. This will allow you to check the light to be certain that it works and can also be used at any time as a "Test Pill" to check out the system.

## Troubleshooting

1. Do you have 12 volt power?
2. Double check your ground.
3. Is the RPM module inserted into the receptacle?
4. If you have checked the above and are still having difficulty, call Auto Meter customer service at (815) 895-8141.

## SERVICE

For service send your product to Auto Meter in a well packed shipping carton. Please include a note explaining what the problem is along with your phone number. Please specify when you need the product back. If you need it back immediately mark the outside of the box "RUSH REPAIR," and Auto Meter will service product within two days after receiving it. (\$10.00 charge will be added to the cost of "RUSH REPAIR.") If you are sending product back for Warranty adjustment, you must include a copy (or original) of your sales receipt from the place of purchase.

## 12 MONTH LIMITED WARRANTY

Auto Meter Products, Inc. warrants to the consumer that all Auto Meter High Performance products will be free from defects in material and workmanship for a period of twelve (12) months from date of the original purchase. Products that fail within this 12 month warranty period will be repaired or replaced at Auto Meter's option to the consumer, when it is determined by Auto Meter Products, Inc. that the product failed due to defects in material or workmanship. This warranty is limited to the repair or replacement of parts in the Auto Meter instruments. In no event shall this warranty exceed the original purchase price of the Auto Meter instruments nor shall Auto Meter Products, Inc. be responsible for special, incidental or consequential damages or costs incurred due to the failure of this product. Warranty claims to Auto Meter must be transportation prepaid and accompanied with dated proof of purchase. This warranty applies only to the original purchaser of product and is non-transferable. All implied warranties shall be limited in duration to the said 12 month warranty period. Breaking the instrument seal, improper use or installation, accident, water damage, abuse, unauthorized repairs or alterations voids this warranty. Auto Meter Products, Inc. disclaims any liability for consequential damages due to breach of any written or implied warranty on all products manufactured by Auto Meter.

FOR SERVICE SEND TO: **AUTO METER PRODUCTS, INC.** 413 W. Elm St., Sycamore, IL 60178 USA (815) 895-8141

2650-440B 4/3/96